

## Description

Cirrus Reflex & transparent Level gauges are widely used for liquid level measurement in Low / High pressure vessels & Boilers. These gauges are rugged, sturdy, have low initial cost & gives easy level reading by viewing the position of liquid through glasses. A square shaped chamber is uniformly machined to have one or more windows on which clear Toughened Borosilicate flat glass is fitted in each window with U-Bolts, gasket & Cover plates. The chamber is connected to integral bonnet isolation Valves for shut-off the liquid flow. Gauge is connected to vessel through various flange / threaded connections. These are manufactured in different material of construction as CS/SS304/SS316/PP/ASTMA105 etc. for normal & high pressure & temperature liquids, with accessories like safety check valves, Mica shields, illuminators, drain valves etc. & are also available in IBR versions for Boilers. Each Level gauge has a pair of isolation valves for liquid inlet flow closing. Due to their sturdy design & wide range of temperature & pressure operation, these are widely used in major industries.

Application : Condensate tanks, Boilers, Pressure vessels, Chemicals, pharmaceuticals, solvents, Coolants, High temperature/pressure liquid storage tanks, lube oil, acids etc

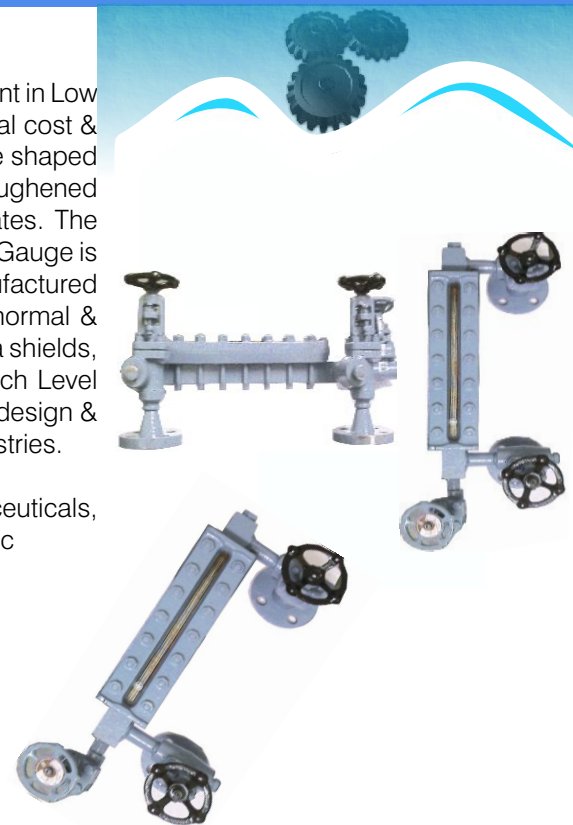

## Features

- ⇒ Sturdy, rugged
- ⇒ Reliable, maintenance free
- ⇒ High temperature & pressure
- ⇒ CS & SS construction
- ⇒ Easy to install & operate.

## Technical Specification

MODEL	CLG -1 & 2
Type	Reflex & Transparent level gauge
C-C distance	2.0 mtr / others
Material of construction	CS / SS 304 / SS 316 /ASTMA105/forged
Mounting	Side
Valve	Isolation valves
Temperature	Amb. ~ 400 °C
Pressure	Upto 250 kg /cm2
Process Connection	Flange / Socket weld
Glass	Toughened borosilicate flat Reflex / Transparent

## Model Selection

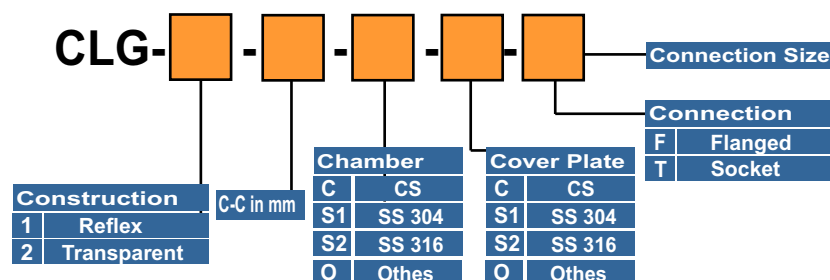

Contact us for other models & specifications not listed here. Due to product enhancement, technical specification may vary.

# Cirrus

## CIRRUS ENGINEERING & SERVICES PVT. LTD.

A-79, 2nd Floor, Vishal Market,  
Tagore Garden Extn.,  
New Delhi - 110027

Tel # 011-25176844, 20902218  
Fax # 011-25195396  
E-mail # cirrusinfo@gmail.com  
# cirrus@vsnl.net

WWW.CIRRUSINDIA.CO.IN

